

Features

- Aluminum enclosure LxWxH: 127X76.2X40mm
- Compact size: 5"x3"
- Natural cooling: 320W
- Forced convection: 600W (12V 25CFM, 24V 25CFM)
- Wide input voltage range: 100-277VAC
- Active PFC function
- LED indicator light
- Output voltage adjustment
- -25°C~+70°C Operating temperature
- Isolation voltage: 3750VAC
- High liability, long lifespan
- Input undervoltage protection, output short circuit protection, overcurrent/overvoltage protection, overtemperature protection

This series is a 600W output power AC-DC switching power supply with an input voltage range of 100-277VAC, it offers both constant current and constant voltage output modes, available in 12V, 19V, 24V, 27V, 36V, and 48V output voltages. With efficiency up to 95%, it operates reliably in environments ranging from -25°C to +70°C. This series features comprehensive protection functions, complies with international safety regulations, and is suitable for applications in industrial automation machinery, industrial control systems, communication equipment, LED systems, smart home technology, electronic instruments, and medical equipment.

Specifications							
Model	Cooling Method	Output Power*	Rated Output Voltage/Current(Vo/Io)	Input Voltage Range	Efficiency (Typ.)*	Output Voltage Adjustable Range ADJ(V)	Max Capacitive Load at Room Temperature
TPS-GSH600S-12V	Natural air cooling	300W	12V/25A	100~277VAC/ 141~390VDC	94%	11.5~12.5V	10000μF
	Forced air cooling	500W	12V/41.67A		93%		
TPS-GSH600S-19V	Natural air cooling	300W	19V/15.8A	100~277VAC/ 141~390VDC	94%	18~20V	8000μF
	Forced air cooling	500W	19V/26.32A		93%		
TPS-GSH600S-24V	Natural air cooling	320W	24V/13.34A	100~277VAC/ 141~390VDC	95%	22~27V	6000μF
	Forced air cooling	600W	24V/25A		94%		
TPS-GSH600S-27V	Natural air cooling	320W	27V/11.85A	100~277VAC/ 141~390VDC	95%	24~29V	5000μF
	Forced air cooling	600W	27V/22.22A		94%		
TPS-GSH600S-36V	Natural air cooling	320W	36V/8.89A	100~277VAC/ 141~390VDC	95%	33~39V	3000μF
	Forced air cooling	600W	36V/16.67A		94%		
TPS-GSH600S-48V	Natural air cooling	320W	48V/6.67A	100~277VAC/ 141~390VDC	95%	44~54V	2000μF
	Forced air cooling	600W	48V/12.5A		94%		
Notes	<p>1.* Under any steady-state conditions, the total output power of the product shall not exceed the rated total power. When the output voltage is increased, the total output power must not exceed the rated output power; furthermore, when the output voltage is increased by more than 5% of the rated voltage, the output power must be reduced to 80% of the rated power. When the output voltage is decreased, the output current must not exceed the rated output current.</p> <p>2.* Efficiency test conditions: 25°C ambient temperature, 230 VAC input; when testing full-load efficiency, the fan must be powered by an external power source, meaning the fan's power loss is not included in the input power.</p> <p>3.* Ripple & Noise Test Method: Connect a 0.1μF ceramic capacitor in parallel with a 47μF electrolytic capacitor at the output terminal; set the oscilloscope bandwidth to 20 MHz.</p> <p>4.* Unless otherwise specified, all typical values are measured under conditions of 230 VAC input and ambient temperature of 25 °C.</p> <p>5.* Voltage regulation: Measured under rated load conditions as the input voltage varies from low to high.</p> <p>6.* Load Regulation: Measured as the output varies from 1% load to 100% load.</p> <p>7.* Accuracy: Includes setting error, voltage regulation, and load regulation.</p> <p>8.* For AC input, the L and N terminals are not polarized; for DC input, L is the positive terminal and N is the negative terminal.</p>						
Notes	<p>*This product does not support inductive loads such as motors, power amplifiers, or audio systems. For bulk orders, please contact customer service to request a custom solution. This product involves high-voltage electricity; please exercise caution to ensure electrical safety.</p>						

Electrical Specifications								
Model		TPS-GSH600S-12V	TPS-GSH600S-19V	TPS-GSH600S-24V	TPS-GSH600S-27V	TPS-GSH600S-36V	TPS-GSH600S-48V	
Output	Rated voltage	12V	19V	24V	27V	36V	48V	
	Current range (Natural cooling)	0-25A	0-15.8A	0-13.34A	0-11.85A	0-8.89A	0-6.67A	
	Current range (25CFM Fan cooling)	0-41.67A	0-26.32A	0-25A	0-22.22A	0-16.67A	0-12.5A	
	Output power (Natural cooling)	300W	300W	320W	320W	320W	320W	
	Output power (25CFM Fan cooling)	500W	500W	600W	600W	600W	600W	
	Efficiency (115VAC/230VAC, Full Load, Min.)	90%/92%	90%/92%	90%/92%	90%/92%	90%/92%	90%/92%	
	Efficiency (115VAC/230VAC, Full Load, Typ.)	92%/94%	92%/94%	92%/94%	92%/94%	92%/94%	92%/94%	
	Ripple voltage	<100mVp-p	<100mVp-p	<150mVp-p	<150mVp-p	<200mVp-p	<200mVp-p	
	Voltage adjustment range (Adjustable resistor)	11.5-12.5V	18-20V	22-27V	24-29V	33-39V	44-54V	
	Voltage accuracy	±1%						
	Voltage overshoot	<10%						
	Line regulations	±0.5%						
	Load regulation	±1%						
	Start-up time	1S (typ.)						
	Rise time	8ms (typ.)						
Hold time	>10ms, 14ms (typ.) 115/230VAC, full load							
Input	Rated voltage	100-240VAC						
	Voltage range	100-277VAC (Refer to the input voltage derating curve)						
	Input frequency	Rated frequency 50/60Hz, operating range 47-63Hz						
	Power factor	>0.98 (full load 115/230Vac)						
	Input current(Max)	6A/115VAC, 3A/230VAC						
	No-load power consumption (Max)	≤2W (Minor low frequency noise at no/light load. Silent version customizable, no-load power ≤4W.)						
	Inrush current (Max)	Cold start: 30A/120VAC, 60A/240VAC						
	Touch current (Max)	0.1mA/240VAC						
Protection	Input undervoltage protection	60-85VAC ±10%						
	Output overcurrent protection	110%-180% of the rated output current, hiccup mode, auto-recovery						
	Output overvoltage protection	110%-125% of rated output voltage, output shut down, auto-recovery after restart						
	Output short-circuit protection	Hiccup mode, auto-recovery after short is removed						
	Overtemperature protection	Primary	Output shuts off, automatic recovery after temperature decreases					
Secondary		turn off output, when the temperature decreases, restart to restore operation						
Environment	Operating temperature & Humidity	-25~+70°C, 20%~90%RH non-condensing (Refer to temperature derating curve for use)						
	Storage temperature & Humidity	-40~+85°C, 10%-95%RH						
	Temperature coefficient	±0.03%/°C						
Safety EMC	Safety standards	MEET IEC/EN62368, GB4943.1						
	EMC	CISPR32/EN55032 CLASS B, EN61000-4-2/3/4/6 CLASS B						
	Lightning surge protection	IEC/EN61000-4-5, line to line ±2KV, line to ground ±2KV						
	Withstand voltage	I/P-O/P: 3750VAC, I/P-FG: 1500VAC, O/P-FG: 1500V						
	Insulation resistance	I/P-O/P, I/P-FG, O/P-FG: >100M Ohm/500VDC						
Other	Fan Auxiliary Power	12V, 19V	Voltage 12V+15%, current 0.6A (Voltage changes proportionally with output voltage adjustment)					
		24V, 48V	Voltage 24V+15%, current 0.3A (Voltage changes proportionally with output voltage adjustment)					
	Remote sense	When RS+ and RS- are connected to the client, they provide remote voltage compensation. If remote voltage compensation is not required, RS+ and RS- should be left floating and must not be shorted, don't connect a load directly.						
	Dimensions	LXWXH: 127X76.2X40mm (±1mm)						
Weight	480±20g							

Product Characteristic Curve

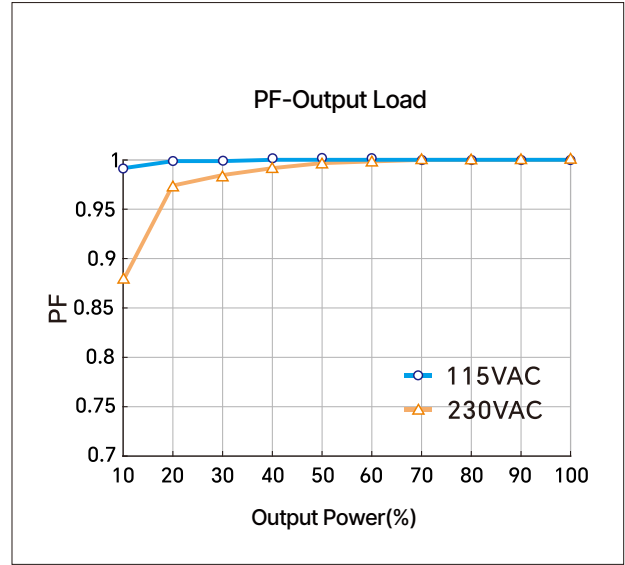
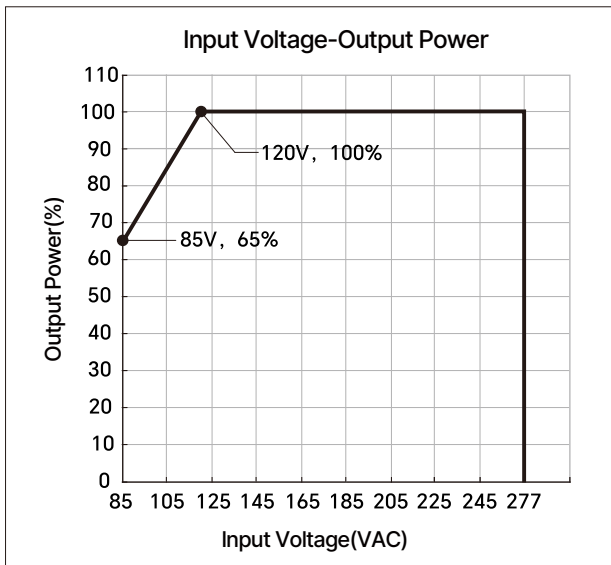
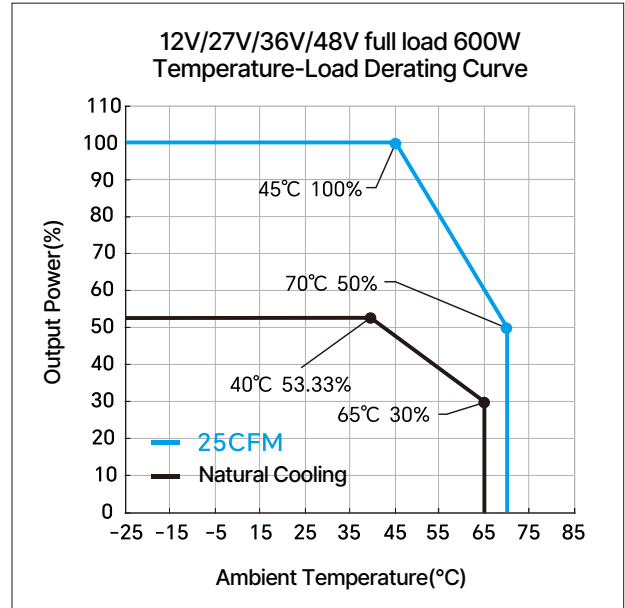
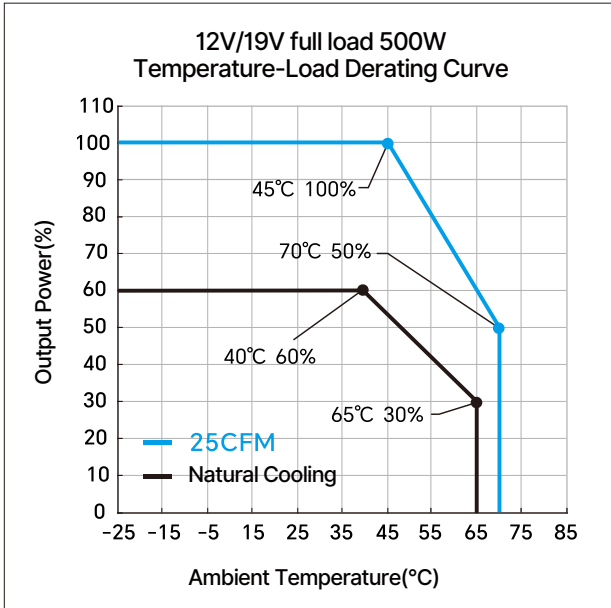

Note: For input voltages of 85~115VAC/120~162VDC, it is necessary to perform input voltage derating on the basis of temperature derating.

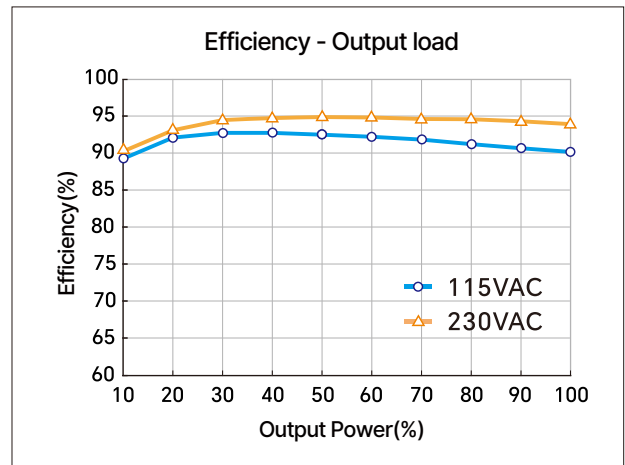
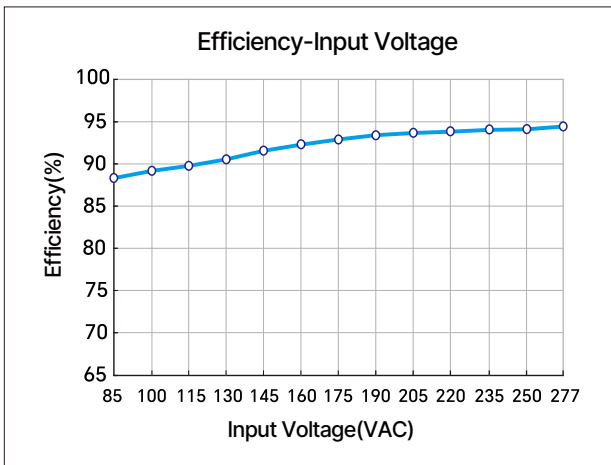

Mechanical Dimensions

Unit: mm(±1mm)

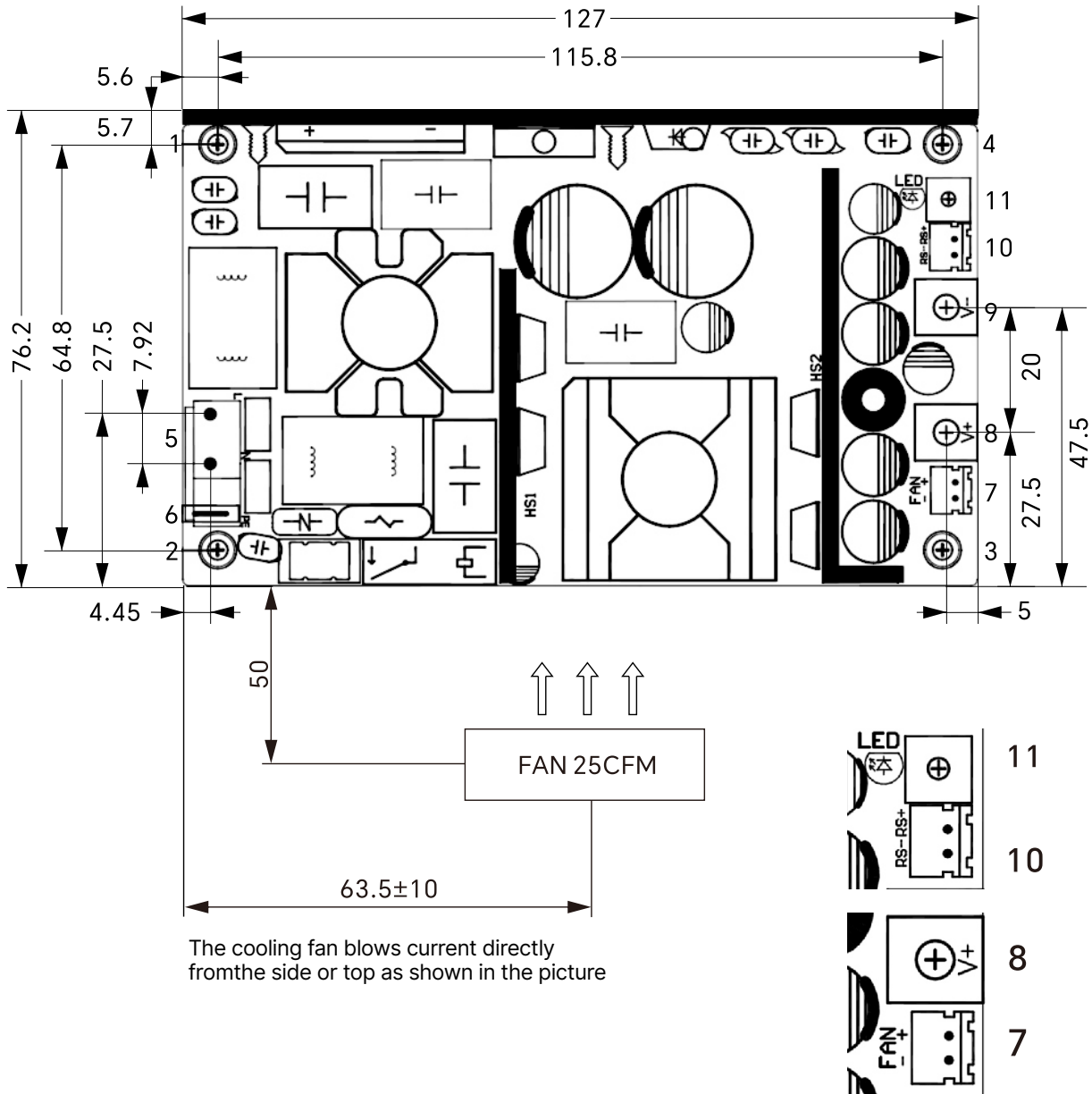

No.	Function	Client-side Connector
1,2,3,4	Mounting Holes	M3 screws, bottom mounting
5	Input Terminal	JST SVH-21T-P1.1 or VH3.96-3P with 1P empty terminal wires
6	Ground Terminal	JST SPS-21T-250 or equivalent
7	Fan Terminal	XH2.54-2P male header or equivalent
8	Output Positive	
9	Output Negative	
10	Remote Sense Terminal	XH2.54-2P male header or equivalent
11	Adjustable Resistor	

- Unit of dimension: mm
- Dimensional tolerance: ±1 mm
- Component layout for reference only; subject to actual product.
- Keep a safety clearance between PCB edge and customer components; 10mm recommended.

External Dimensions

Unit: mm(±1mm)

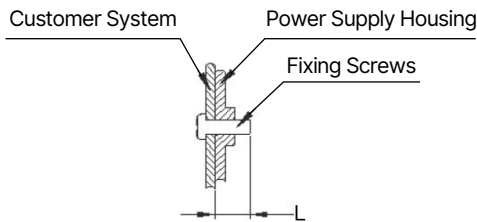
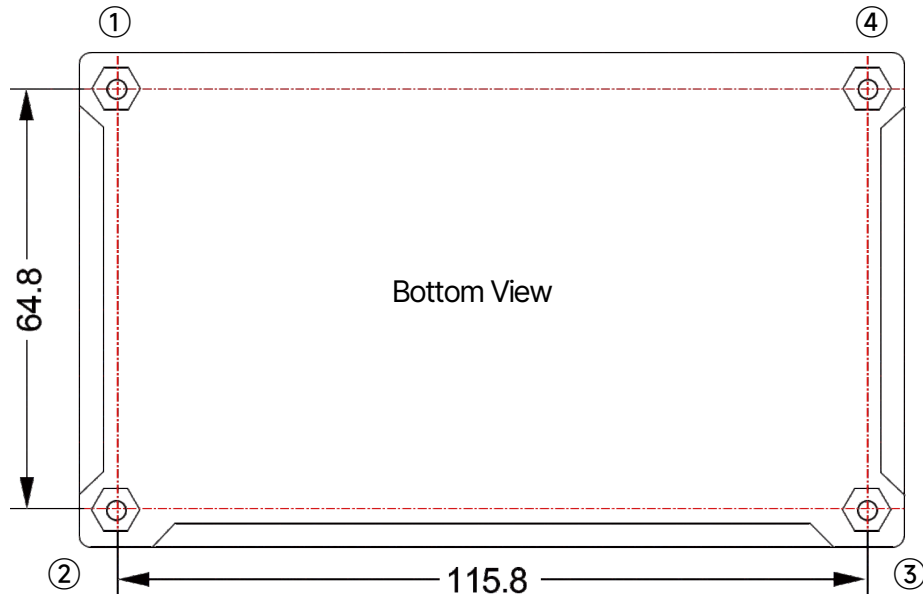

Mounting Position	Screw Specification	L (Recommended)	Torque (Max.)
①~④	M3	2MM	0.4N.m

For bottom mounting, M3 screws are recommended for mounting holes No.1~4 on the base. Reserve space for a 2 mm screw penetration to ensure secure installation.

Remote Sensing Function Wiring Diagram

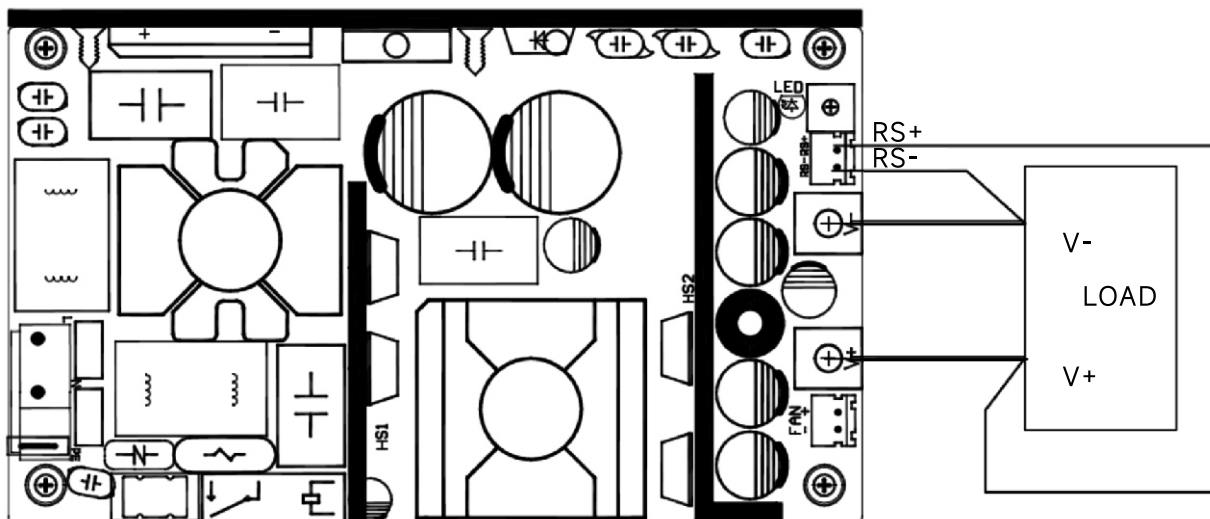

Notes:

- RS+ and RS- must not be short-circuited or reversely connected, otherwise the power supply will be damaged.
- The remote sensing compensation function compensates for voltage drop on output cables, which equals the total voltage drop of the positive and negative output cables. The compensated voltage drop is recommended not to exceed 1 V. Use thicker wires or shorten cable length to reduce voltage drop.
- Twisted pair wires shall be used for connections between signal terminals and load terminals when the remote sensing compensation function is activated.

Wiring Schematic

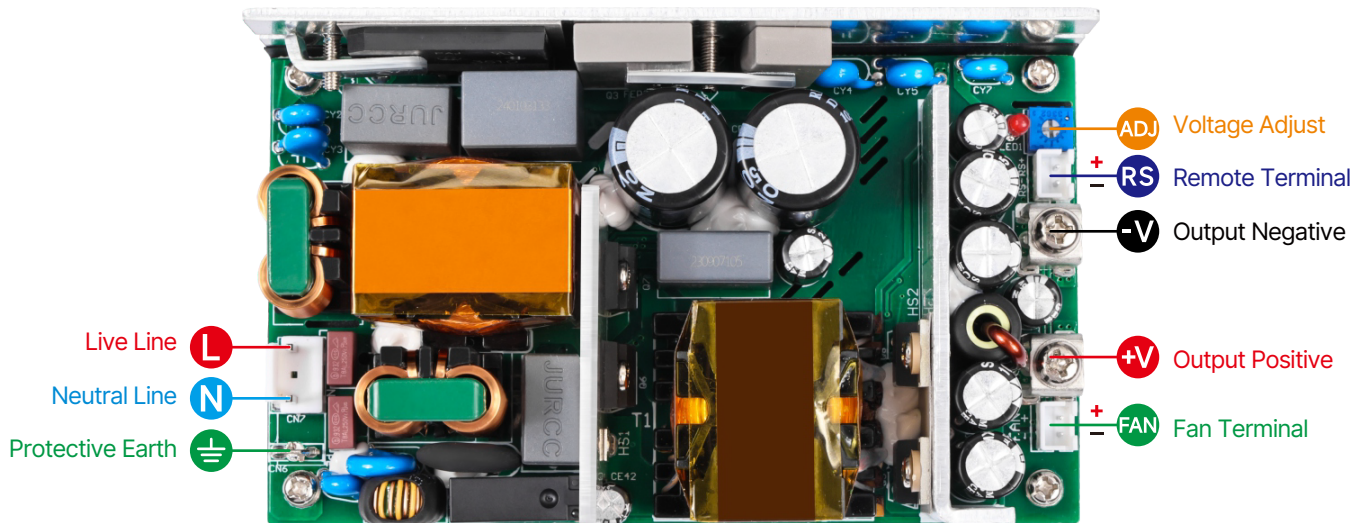

Note 1: Fan Port Specification: For output voltages of 12V/19V, use a 12V 0.6A fan; For output voltages of 24V/27V/36V/48V, use a 24V 0.3A fan.

Note 2: Do not short-circuit fan wiring. Confirm positive and negative poles before wiring.

Note 3: Never short-circuit the remote sense terminals.

Mounting Schematic

Unit: mm(±1mm)

External Aluminum Plate Installation

To comply with the derating curve, the unit must be mounted on a smooth aluminum plate with an equal or larger metal surface area. The recommended aluminum plate dimensions are shown in the figure below. For optimal heat dissipation, secure the power supply tightly at the center of the aluminum plate. If a fan is equipped, arrange it according to actual application conditions.

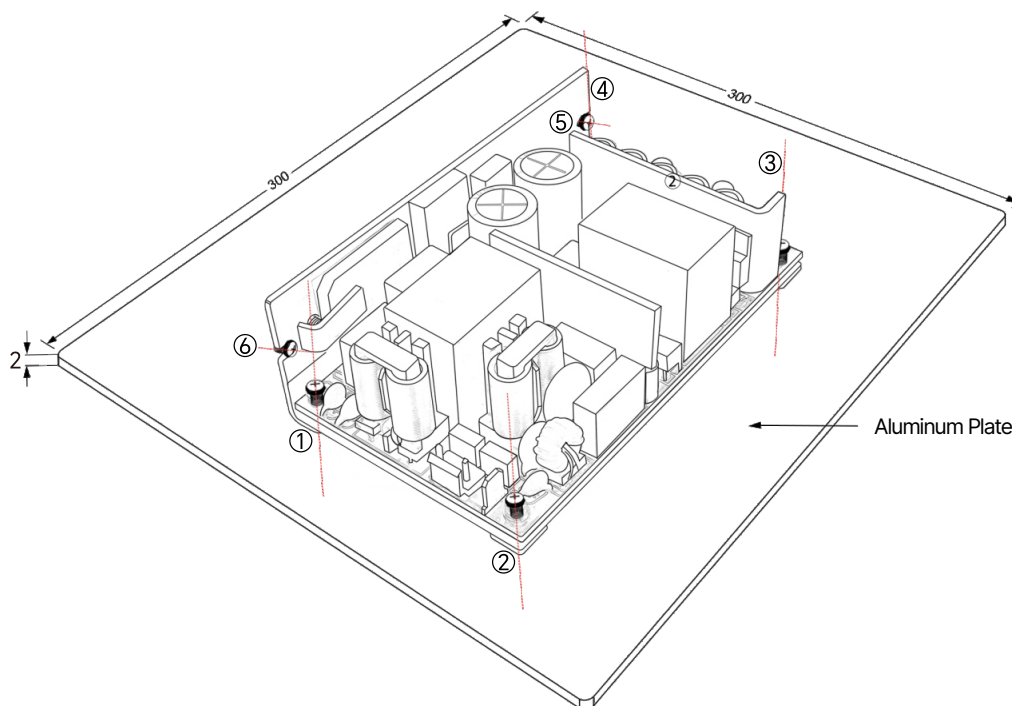

Bottom Mounting: M3 screws are recommended for mounting holes No.1 to 4 on the bottom. Allow a 2 mm screw penetration within the reserved clearance to guarantee firm installation.

Front Mounting: If the power module needs to be mounted from the front, remove the diagonally symmetric screws first, then use longer screws to fasten from the front. M3 screws are recommended. Select screw length according to actual application requirements to achieve stable installation of the power module.