

Lyra

60/80

kW-DC

Fast Charging

*Simultaneous
charging*





01

EV Fast charging points

Intro

The Lyra 60 EV charger, manufactured by Floox in Barcelona, is a high-power charging unit with compact dimensions of 585 x 290 x 1124(h) mm and a weight of 120 kg. With a power output of 60kW or 80kW (can also be limited to 40kW or 50kW via software), this charger offers simultaneous charging capacity for two vehicles in direct current (DC), making it a versatile solution for installation in a variety of environments, such as companies, petrol stations, public plazas, and transport fleets.

60/80 kW - DC



Perfect fit for:

Street parkings

Public parking operators

Mid-size filling stations

Transport fleets



High
Power



Simultaneous
charging for two
vehicles



User
authentication



LCD Display
12,1"



OCPP
Compliant



Autocharge



IP54



All-in-one
solution



General Specifications

POWER SPECIFICATIONS	Input voltage	3Φ 380~415 Vac (±15%)
	AC Input connection	3P+N+PE, TN/TT/IT
	Maximum input current	120A (60kW) / 160A (80kW)
	Frequency	50 Hz/60 Hz
	Power factor	>0.99
	Efficiency	>97%, optimum point V/I
	DC Output voltage range	CCS2: 155~950 Vdc / 200A (60kW) - 250A (80kW) max
	Maximum output power	60 kW - 80 kW
	Voltage accuracy	±2%
	Current accuracy	±2%
USER & CONTROL INTERFACE	Display	Touch panel 12.1"
	Interface protocol	OCPP 1.6J (coming soon OCPP 2.0.1) JSON over WebSocket Secure connection to OCPP server using TLS and user authentication
	Optional	RFID > supports ISO 14443A/B, ISO 15693 FeliCa Lite-S (RCS966) VISA Payment Autocharge: Automatic authentication and charging start using the vehicle's unique identifier
COMMUNICATIONS	External	Ethernet & 3G/4G (Wi-Fi optional)
	Internal	CAN bus/RS485
ENVIRONMENT	Operating temperature	-30°C~50°C (optional extended temperature range)
	Maximum relative humidity	5%~95% RH, non-condensed
	Altitude	≤ 2000 m
	IP/IK Level	IP54/IK10
	Cooling	Forced air
MECHANICS	Size	585 x 290 x 1124 mm (Body without handles)
	Weight	≤ 120-130 kg
	Hose length	3 m (other lengths are optionally available)
PACKAGING	Gross weight	≤ 200-210 kg
	Wooden box size	1140 x 980 x 2070 mm
	Storage temperature	-40°C ~ 60°C
PROTECTIONS	Input protections	OVP, OCP, OPP, OTP, UVP, RCD, SPD
	Output protections	OCP, SCP, OVP, LVP, OTP, IMD
STANDARDS & CERTIFICATIONS	Certifications	IEC 61851-1, IEC 61851-23, IEC 61851-21-2 MID (CH-MI003-21039)
	Eichrecht certification (optional)	Class B (EN 50470-4:2023) PTB approval (DE-20-M-PTB-0075)
	Security	CB, CE
	Charging interface	CCS2, DIN 70121, ISO15118

03

Dimensions

Lyra wallmounted

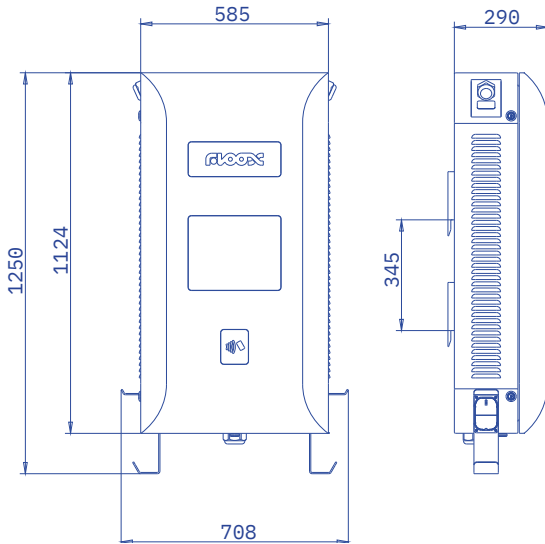

Lyra with stand

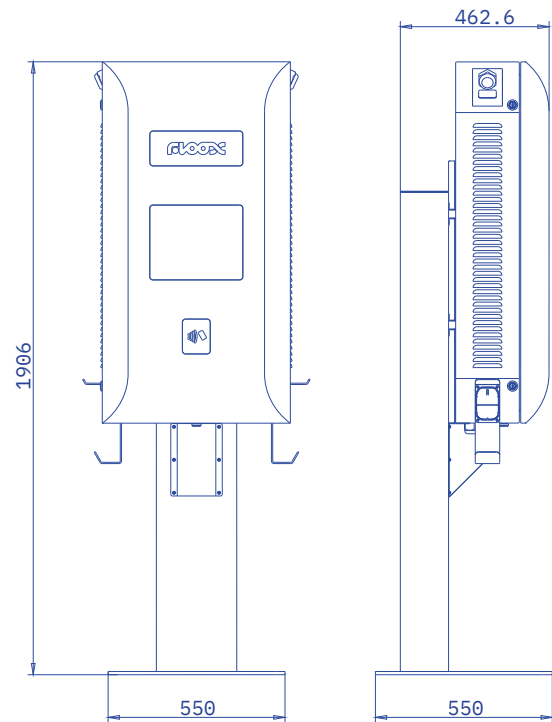

Lyra with trolley

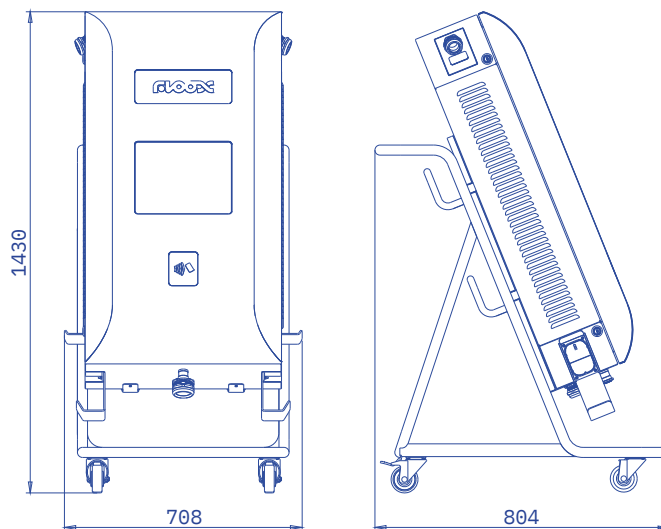

04

Product reference

Reference	Description
LYRA0600000000000000	LYRA 60kW - 2x CCS2 (Standard)
LYRA0800000000000000	LYRA 80kW - 2x CCS2 (Standard)
7000019101	Stand (Optional)
7000018502	Trolley (Optional)